

Washdown Scales

SC/SE

Series



SUBMERSIBLE



AND ...Clearly a Better Value
A&D Company, Limited

IP68 Washdown – A New Standard of Platform Scales for Harsh Environments

The SC/SE Series, equipped with a completely sealed indicator, achieves a submersible level of watertightness, while providing high accessibility and excellent weighing performance, including stabilization in just 1 second! * 1 m under water for 24 hours*



SC Series
Premium Resistance to Hostile Environments!

Stainless steel
(SUS304) frame



SC-30KAM
60KAM
150KAM



SC-60KAL
150KAL



SE Series

High Resistance to Hostile Environments!

Steel frame



SE-30KAM
60KAM
150KAM



SE-60KAL
150KAL



Features

- IP68 dust and water-proof (submersible)
- Washdown construction for easy cleaning
- 4500 hours of continuous operation with 6 D batteriesⁱ
- Supersized LCD of 39 mm character height
- Easily switchable, multiple weighing units (kg, lb, oz, and pcs)
- High speed stabilization of 1 second
- Stainless steel weighing pan (SC: SUS304, SE: SUS430)
- Waterproof and corrosion-resistant load cellⁱⁱ
- Quick USB interfaceⁱⁱⁱ and RS-232C + comparator relay output available as options

i) Batteries are not included.

ii) Aluminum anodized and coated with epoxy resin with protective silicon over wiring.

iii) Cables are not included.



Easily removable battery unit



Battery life indicator



Specifications

		SC-30KAM SE-30KAM	SC-60KAM SE-60KAM	SC-150KAM SE-150KAM	SC-60KAL SE-60KAL	SC-150KAL SE-150KAL
kg	Capacity	30	60	150	60	150
	Min. display	0.01 0.005 *	0.02 0.01 *	0.05 0.02 *	0.02 0.01 *	0.05 0.02 *
lb	Capacity	66	130	330	130	330
	Min. display	0.02 0.01 *	0.05 0.02 *	0.1 0.05 *	0.05 0.02 *	0.1 0.05 *
oz	Capacity	1050	2100	5200	2100	5200
	Min. display	0.5 0.2 *	1 0.5 *	2 1 *	1 0.5 *	2 1 *
Number of samples		5 pieces (Can be changed to 10, 20, 50 or 100)				
Maximum count		60,000 pcs	60,000 pcs	75,000 pcs	60,000 pcs	75,000 pcs
Minimum unit weight		0.0005 kg	0.001 kg	0.002 kg	0.001 kg	0.002 kg
Repeatability (Std. deviation)		0.005 kg	0.01 kg	0.02 kg	0.01 kg	0.02 kg
Linearity		±0.01 kg	±0.02 kg	±0.05 kg	±0.02 kg	±0.05 kg
Sensitivity drift		±20 ppm / °C (5 °C to 35 °C / 41 °F to 95 °F)				
Display		7 segment LCD (Character height: 39 mm)				
Display update		10 times per second				
Operating conditions		-10 °C to 40 °C / 14 °F to 104 °F, 85%R.H. or less (no condensation)				
Power supply		Size D (R20P / LR20) batteries x 6				
Battery operation		Approximately 4,500 hours using alkaline batteries				
Weighing pan size		300 x 380 mm / 11.8 x 15.0 in.			390 x 530 mm / 15.4 x 20.9 in.	
Dimensions	SC	300(W) x 543(D) x 717(H) mm			390(W) x 688(D) x 717(H) mm	
		11.8(W) x 21.4(D) x 28.2(H) in.			15.4(W) x 27.1(D) x 28.2(H) in.	
	SE	300(W) x 582(D) x 722(H) mm			390(W) x 732(D) x 722(H) mm	
		11.8(W) x 22.9(D) x 28.4(H) in.			15.4(W) x 28.8(D) x 28.4(H) in.	
Mass (approximate)		12 kg / 26.5 lb			16 kg / 35.3 lb	
Calibration weight (factory setting)		30 kg	60 kg	150 kg	60 kg	150 kg
		60 lb	120 lb	300 lb	120 lb	300 lb

* Factory setting

Options

SCE-02 Quick USB interface

SCE-03 RS-232C + comparator relay output

* SCE-02 and SCE-03 cannot be used at the same time.

* The SC / SE is not IP68 compliant with SCE-02 or SCE-03.

External Dimensions (mm/inches)

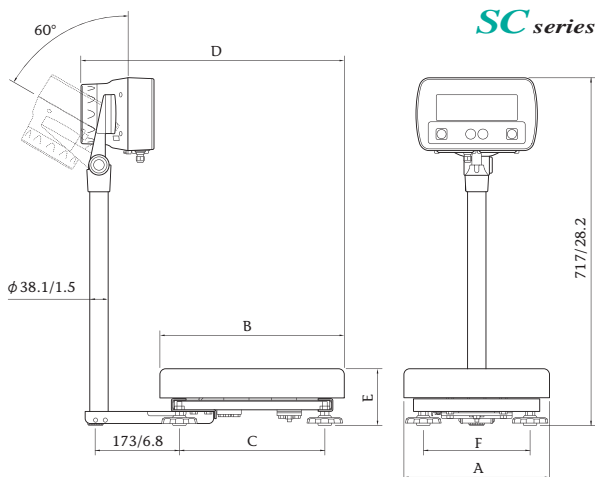

Model	A	B	C	D	E	F
SC-30KAM / 60KAM / 150KAM	300/11.8	380/15.0	300/11.8	543/21.4	117/4.6	220/8.7
SC-60KAL / 150KAL	390/15.4	530/20.9	440/17.3	688/27.1	123/4.8	300/11.8

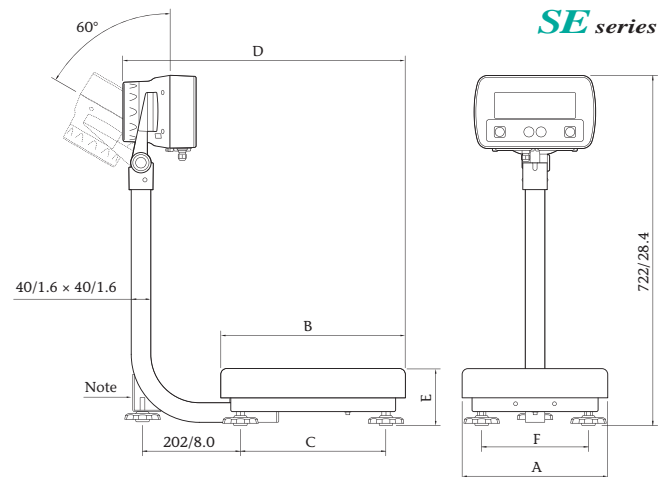

Model	A	B	C	D	E	F
SE-30KAM / 60KAM / 150KAM	300/11.8	380/15.0	300/11.8	582/22.9	118/4.7	220/8.7
SE-60KAL / 150KAL	390/15.4	530/20.9	440/17.3	732/28.8	128/5.0	300/11.8

Note) The pole support foot is for the SE-30KAM/60KAM/150KAM only.



WWW.HOSKIN.CA

• INTEGRATED SYSTEMS • RENTALS • SERVICE
• ENVIRONMENTAL • INSTRUMENTATION • MATERIALS TESTING

Vancouver | Burlington | Montréal | Edmonton