

# ROCK SOLID™ SCALES





**FC3-C** SERIES





# FG-K SERIES

## Fast Response for Efficient Weighing Applications

The New FG-K series combines fast response time with accurate measurement to suit any weighing application.

- RI-2-3** • **Three weighing resolutions** Normal (1/3000), \*High (1/6000 for 30kg and 60kg weighing capacity) and \*Higher resolution (1/12000 for 60kg and 1/15000 for 30kg and 150kg weighing capacity) \*non NTEP settings
- 
**Counting function** Useful in piece counting applications with sample size of 5, 10, 20, 50 and 100 pcs for unit weight registration
- 
**Comparator function** HI / OK / LO comparator indication and optional relay output ( FG-24) for checkweighing applications
- 
**Calibration function** Simple calibration with external mass

- 
**Auto-power OFF function** Saves power consumption by automatically switching itself off when the scale displays zero for approx. five minutes
- Low power supply indication** Alerts user to check AC power supply “Lb1” or batteries “Lb0”
- Filtering function** Filtering levels of slow, normal and fast are selectable to suit environmental conditions
- Leveling feet and bubble** Easy to adjust the level of the scale for accurate weighing
- 
**Optional RS-232C and Comparator Output** Easy to connect peripherals such as printer, comparator light and computer for weighing system applications

### Display Features





# ROCK SOLID PERFORMANCE

## Low Profile Models

FG-KBM (Medium Pan)

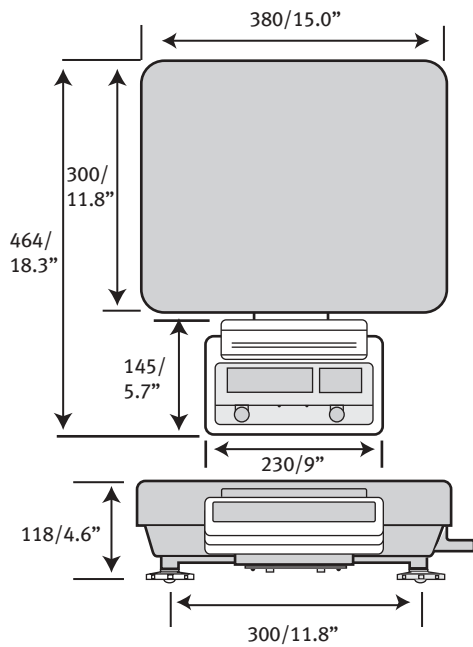

## Column Models

FG-KAM (Medium Pan)

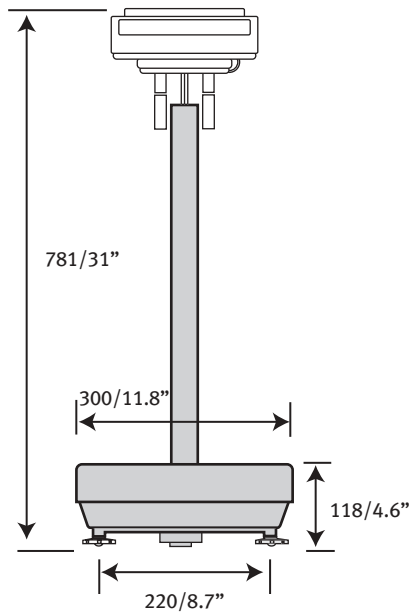

## Column Models

FG-KAL (Large Pan)

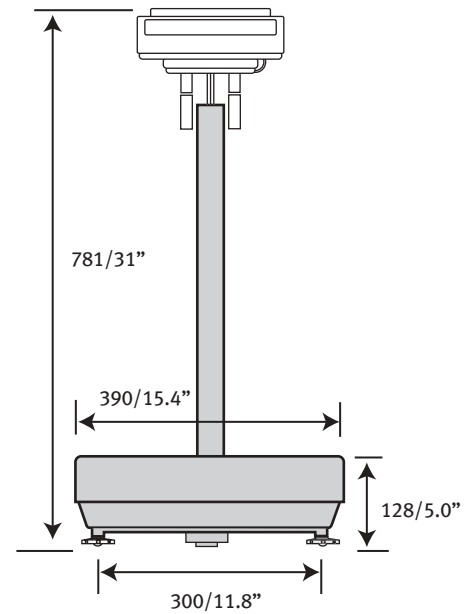

UNIT=mm/in

## Built to last, easy to operate

- One second response time
- Three weighing resolutions
- AC or battery operation
- Stainless steel weigh pan  
M (300 x 380mm), L (390 x 530mm)



FG-30KBM  
FG-60KBM  
FG-150KBM



FG-30KAM  
FG-60KAM  
FG-150KAM



FG-60KAL  
FG-150KAL

## Specifications

	FG-30KAM FG-30KBM	FG-60KAM FG-60KBM	FG-150KAM FG-150KBM	FG-60KAL	FG-150KAL	FG-200KAL
Weight capacity (kg)	30	60	150	60	150	200
Min. display (kg)	0.01*	0.02*	0.05*	0.02*	0.05*	0.05*
	0.005	0.01	0.02	0.01	0.02	0.02
	0.002	0.005	0.01	0.005	0.01	0.01
Weight capacity (lb)	60	150	300	150	300	400
Min. display (lb)	0.02*	0.05*	0.1*	0.05*	0.1*	0.1*
	0.01	0.02	0.05	0.02	0.05	0.05
	0.005	0.01	0.02	0.01	0.02	0.02
Weight capacity (oz)	960	2400	4800	2400	4800	6400
Min. display (oz)	0.5*	1*	2*	1*	2*	2*
	0.2	0.5	1	0.5	1	1
	0.1	0.2	0.5	0.2	0.5	0.5
No. of samples	5 (can be changed to 10, 20, 50 or 100) pieces					
Max. counts	120,000 pcs	96,000 pcs	120,000 pcs	96,000 pcs	120,000 pcs	160,000 pcs
Min. unit weight	0.25 g	0.625 g	1.25 g	0.625 g	1.25 g	1.25 g
Repeatability (Std. deviation)	0.05 kg	0.01k g	0.02 kg	0.01 kg	0.02 kg	0.02 kg
Linearity error	0.01 kg	0.02 kg	0.05 kg	0.02 kg	0.05k g	0.05k g
Sensitivity drift	20 ppm / C (10 °C~30 °C / 50 °F~86 °F)					
Display	7 segment LCD display (Character height 26 mm)					
Display update	10 times per second					
Operating temp	-10 °C~40 °C / 14 °F~104 °F, less than 85% RH (no condensation)					
Power supply	AC adapter or C size (R14P / LR14) x 4 batteries					
Battery operating	Approximately 150 hours with alkaline dry cell battery					
Weighing pan size	300 x 380 mm / 11.8 x 15.0 inches			390 x 530 mm / 15.4 x 20.9 inches		
Dimension	FG-KAM: 300(W) x 624(D) x 781(H) mm / FG-KBM: 380(W) x 464(D) x 118(H) mm			390(W) x 771(D) x 781(H) mm		
Weight (approximately)	FG-KAM: 11.2 kg / FG-KBM: 9.7 kg			16.4 kg		
Calibration weight (Factory setting)	30 kg / 60 lb	60 kg / 150 lb	150 kg / 300 lb	60 kg / 150 lb	150 kg / 300 lb	200 kg/400 lb

\* Legal for Trade Setting

## Options

- FG-23 RS-232C serial interface  
 FG-24 RS-232C serial interface and comparator relay output  
 FG-25 Display Wall Mount Bracket  
 FG-26 Carrying Handle

## Model Selection Guide

Capacity	Column	Pan Size	Model Number
30kg / 60lb	No	M	FG-30KBM
30kg / 60lb	Yes	M	FG-30KAM
60kg / 150lb	No	M	FG-60KBM
60kg / 150lb	Yes	M	FG-60KAM
60kg / 150lb	Yes	L	FG-60KAL
150kg / 300lb	No	M	FG-150KBM
150kg / 300lb	Yes	M	FG-150KAM
150kg / 300lb	Yes	L	FG-150KAL
200kg / 400lb	Yes	L	FG-200KAL

## Accessories

- AD-8121B Dot Matrix Compact Printer  
 AD-8118B Universal Printer  
 AD-8951 Comparator Light\*  
 \*Requires FG-24 and AX-KO1557-W200



AD-8121B  
Dot Matrix  
Printer



AD-8951 -  
Light Pole



[WWW.HOSKIN.CA](http://WWW.HOSKIN.CA)

- INTEGRATED SYSTEMS • RENTALS • SERVICE
- ENVIRONMENTAL • INSTRUMENTATION • MATERIALS TESTING

Vancouver | Burlington | Montréal | Edmonton