

# AD-4328

## Basic Weighing Indicator

The AD-4328 is a simple weighing indicator that converts and displays load cell outputs as weights. The AD-4328 satisfies all basic requirements for platform, hopper and packer scales.

### Display

- Large (character height 14.2mm) LED display for weights and tare values.
- Optional stand available
- Waterproof front panel (IP-65 compliant)

### Weighing Functions

- Checkweighing mode (3 levels) for comparing weight with upper and lower limits.
- Setpoint comparison for batching applications
- Manual and automatic comparator and accumulated data storage to memory

### External I/O

- Control Inputs (3 standard)
- Current Loop Output (for connection to A & D peripheral devices)
- Optional Items
- RS-232C, RS-422/485, Relay output, Parallel BCD output

### Digital Calibration Function

### Power Supply

- DC9V (AC adapter or direct input to the terminal) AC adapter is optional

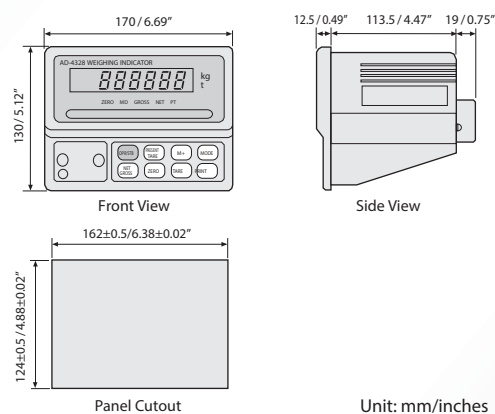

# AD-4329A

## Basic Weighing Indicator

The AD-4329A is equipped with a triple-range function and is ideal for scales with multiple weighing intervals. The AD-4329A is perfect for a diverse array of applications such as hoppers, packers and check-weighing scales.

### Dual Range/Triple Range

- Can switch between three ranges by setting combinations of capacity and minimum display.

### Display

- Vacuum Fluorescent Display (VFD) with 13mm characters

### Weighing Functions

- Checkweighing mode (3 levels) for comparing weight with upper and lower limits.
- Setpoint comparison for batching applications
- Manual and automatic comparator and accumulated data storage to memory

### External I/O

- 7 Control Input nodes
- Standard interface RS-232C,
- 20mA Current Loop (for use with A & D peripheral devices)
- Optional Items
- RS-422/485, Relay Output, Parallel BCD Output, Analog Output (4-20mA)

### Digital Calibration Function Power Supply

- AC100/120/200/220/240V (Please request preferred voltage rating at time of order)

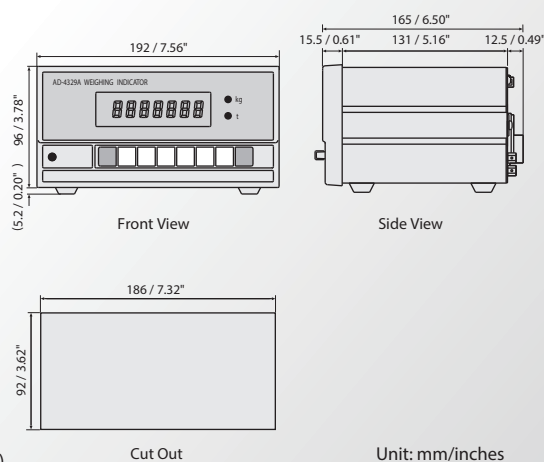

[WWW.HOSKIN.CA](http://WWW.HOSKIN.CA)

- INTEGRATED SYSTEMS • RENTALS • SERVICE
- ENVIRONMENTAL • INSTRUMENTATION • MATERIALS TESTING

Vancouver | Burlington | Montréal | Edmonton