



Features

- Measures 4 pollutant gases. Available gases: NO₂, NO, CO, O₃, SO₂, and H₂S
- Intelligent algorithms that compensate for environmental conditions and for the aging of the sensor element
- Compact design; easy to deploy in the field
- Low power consumption (typically 0.5 W)
- Wireless Internet connection with Vaisala Multi-Observation Gateway MOG100
- RS-232 and RS-485 interfaces for local connectivity (such as Modbus® support)
- Easy integration and open API

Vaisala Air Quality Transmitter AQT400 Series measures the pollution content of ambient air. The series consists of 2 products, AQT420 and AQT410.

Applications

- Air quality networks
- Industrial emission monitoring
- Safety monitoring
- Roadside monitoring
- Building automation
- Air quality research

New value in air quality measurements

AQT400 series revolutionizes air quality measurements. It offers totally new value for money by measuring up to 6 most important pollutants in one compact package.

The AQT400 series comes in 2 versions: AQT410 for gases only and AQT420 for gases and particles. AQT410 is available in 3 different gas configurations:

- NO₂, NO, O₃, and CO
- NO₂, O₃, CO, and SO₂
- NO₂, CO, SO₂, and H₂S

These can be complemented with PM_{2.5} and PM₁₀ measurements by selecting the AQT420 version.

The measurement performance of AQT400 series is based on proprietary advanced algorithms that enable parts per billion (ppb) measurements at an affordable price by using electrochemical sensors. The algorithms compensate for the impact of ambient conditions and aging on the sensor elements and remove the need for costly gas sampling and maintenance equipment.

Easy to deploy in networks

AQT400 series is specifically designed for air quality monitoring networks in urban areas with traffic, road networks, or around industrial sites and transportation hubs. Thanks to its small weight and compact size, it is ideally suited for deployment even in large air quality networks.

The measurement data is sent wirelessly to a web-based database with a gateway solution or is available locally through a serial interface. Depending on local conditions, AQT400 series devices have a maintenance and calibration interval of 24 ... 36 months.

Technical Data

Gas measurement performance

Gas	Range	Detection limit	Accuracy in field conditions ¹⁾
NO ₂	2000 ppb	5 ppb	±25 ppb
NO ²⁾	2000 ppb	5 ppb	±25 ppb
O ₃	2000 ppb	5 ppb	±60 ppb
CO	10 000 ppb	10 ppb	±200 ppb
SO ₂	2000 ppb	5 ppb	±50 ppb
H ₂ S	2000 ppb	5 ppb	±50 ppb

1) 90 % confidence interval in comparing with reference instrument, includes T and %RH dependence in typical field conditions and sensor drift during calibration interval. Electrochemical cell replacement interval 24-36 months, depending on local conditions.

2) NO is an alternative to SO₂.

Particle measurement performance

Particle counter channels	PM _{2.5} and PM ₁₀
Particle diameter range	0.6 ... 10 µm (spherical equivalent)
Sampling time	60 s
Sampling interval	10 min
Sample flow rate	0.9 SLM
Measurement range	PM _{2.5} : 0 ... 2000 µg/m ³ PM ₁₀ : 0 ... 5000 µg/m ³
Measurement resolution	0.1 µg/m ³

Humidity, temperature, and pressure measurement performance

Humidity accuracy	0 ... 90 %RH: ±5 %RH 90 ... 100 %RH: ±8 %RH
Humidity resolution	0.1 %RH
Temperature accuracy for sensor element at +20 °C (+68 °F)	±0.3 °C (0.17 °F)
Temperature resolution	0.1 °C
Pressure accuracy	±10 hPa
Pressure resolution	1 hPa

Ambient condition measurements indicative primarily for compensation purposes

Operating environment

Operating temperature	-30 ... +40 °C (-22 ... +104 °F) Limited performance: -40 ... +50 °C (-40 ... +122 °F)
Operating humidity	15 ... 95 %RH, non-condensing
Operating pressure	800 ... 1150 hPa
EMC compliance	EN/IEC 61326-1 EN 55032 Class B
IP rating	IP65

Inputs and outputs

Operating voltage	8 ... 30 VDC
Power consumption	AQT420: • Typical: 1.3 W • Maximum: 2.6 W AQT410: • Typical: 0.9 W • Maximum: 1.4 W

Data connection specifications

Data protocols	Modbus® ASCII Modbus® RTU ASCII CSV
Serial data interface	RS-485
Maintenance interface	RS-232

Mechanical specifications

Dimensions (H × Ø)	AQT420: 208 × 132 mm (8.19 × 5.20 in) AQT410: 128 × 132 mm (5.04 × 5.20 in)
Weight	AQT420: 1.25 kg (2.76 lb) AQT410: 0.7 kg (1.52 lb)
Material, base module	Anodized aluminum
Material, radiation shield	Polycarbonate (PC)
Color, radiation shield	White (RAL9003)
Power and data connector	Standard 8-pin M12 male

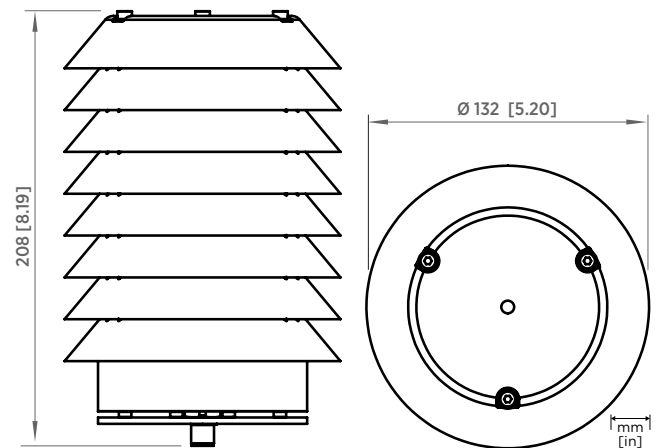

AQT420 dimensions

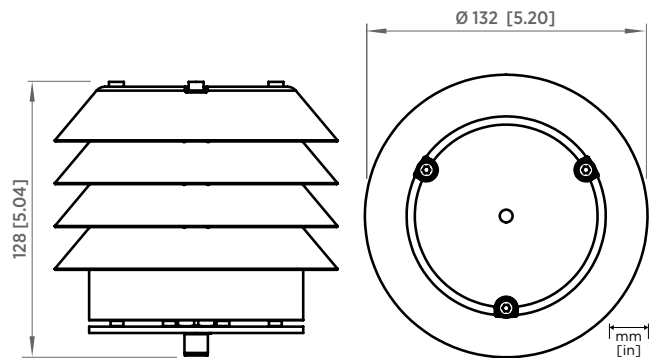

AQT410 dimensions



WWW.HOSKIN.CA

• ENVIRONMENTAL • INSTRUMENTATION • MATERIALS TESTING
• INTEGRATED SYSTEMS • RENTALS • SERVICE

Vancouver | Oakville | Montréal | Edmonton