



## RHM40L

### Coriolis Mass Flow Meter for Demanding Applications

#### Features

- Standard pressure ratings up to 433 bar (6280 psi)
- Temperature ratings from -196 to 350°C (-320 to 662°F)
- Mass flow uncertainty down to 0.15%
- Density uncertainty down to 0.0025 kg/liter
- Repeatability better than 0.05%
- Typical measuring ranges between 1500 and 15 kg/min
- Accurately measure low flow rates down to 12.5 kg/min
- Unique robust torsion driven oscillation system
- Rheonik **AnyPipeFit Commitment** brings you the possibility to get any custom process connection type and size for savings on installation costs. Compact design with minimal footprint
- Approved for use in hazardous areas
- Stainless steel case

#### Applications

- General Flow Control
- Plant Balance
- Terminal Transfer
- High Temperature Fluids
- Viscous Fluids
- Mixing, Blending, Batching
- Barge, Ship, Rail Car and Truck Filling

#### Rheonik Sensor Benefits

- Torsion oscillator design assures a stable and drift free measurement with excellent signal to noise ratios
- Resilient to external noise and vibration
- Insensitive to pipe pressure changes
- Robust tube wall thickness provides increased operational safety in abrasive applications
- Corrosion resistant
- Long sensor life guaranteed due to low mechanical stresses in the meter mechanism
- No moving parts to wear or fail

## General Specification Overview

|   |   |
|---|---|
| <b>Nominal Flow (<math>Q_{nom}</math>)*</b>   | 1500 kg/min (3307 lb/min)   |
| <b>Minimum Flow (<math>Q_{min}</math>)*</b>   | 30 kg/min (66.2 lb/min)   |
| <b>Serial Tube/ Single Path</b>               | Flow rates $Q_{nom}$ and $Q_{min}$ will be 50% of the above listed parallel/dual tube version   |
| <b>Operating Temperature</b>                  | Fluid from -196°C to 350°C (-320°F to 662°F), see options in Part Number Code<br>Ambient from -50°C to 80°C (-58°F to 176°F), optional up to 210°C (410°F)  |
| <b>Pressure Ratings</b>                       | Up to 433 bar / 6280 psi - dependent upon material  |
| <b>Electrical Connection</b>                  | Cable entry M25 x 1.5 (standard), M20 x 1.5, ½" NPT, ¾" NPT (optional)<br>Max. cable length to remote RHE transmitter 30m / 98ft  |
| <b>Sensor Enclosure Materials</b>             | Stainless steel (standard), 316 stainless steel (optional)<br>Epoxy coated aluminum terminal box (standard), 316 stainless steel terminal box (optional)  |
| <b>Enclosure Type</b>                         | Protection class IP65 (standard); IP 66 / NEMA 4X (optional)  |
| <b>Wetted Materials</b>                       | 1.4571 (316Ti), 2.4602 (Alloy C22), Tantalum, 1.4410 (SuperDuplex)<br>Additional/customer specific materials available upon request   |
| <b>Process Connections</b>                    | Nearly any - <b>the RHEONIK AnyPipeFit Commitment</b> . Consult factory for types/sizes not listed in this data sheet   |
| <b>Pressure Rating Compliance</b>             | Europe – PED: Module A2, Module B3.2+C2   |
| <b>Certifications and Approvals</b>           | ATEX / IECEx Approvals for zone 0, 1, 2 (suitably rated RHE transmitter required)<br>North American Approvals for Class I, Div. 1, Groups ABCD (suitably rated RHE transmitter required)<br>American Bureau of Shipping (ABS) Product Type Approval for use on marine vessels   |
| <b>Documentation, Testing and Inspection</b>  | All sensors are hydro tested, calibrated and supplied with a traceable calibration certificate. Customized calibration and testing services available   |
| <b>Project Documentation and QA, Services</b> | Rheonik offers a full set of services for large and complex engineering projects. Typical services offered are, but not limited to: <ul style="list-style-type: none"> <li>• Certificates of origin and conformity, mill certificates</li> <li>• Data books including WPAR, WQS, NDT, test &amp; quality plans, functional testing, calibration procedures, customized packing, factory acceptance etc.</li> <li>• Start up and commissioning services on/offshore</li> </ul> |
| <b>Options</b>                                | Enclosure heating for high temperature applications<br>Cleaning for oxygen service<br>Full service painting to project specifications – consult factory   |

\* At  $Q_{nom}$  pressure drop across a parallel tube sensor will be approximately 1.5 bar (21 psi) for H<sub>2</sub>O. Sensors can be operated at higher flow rates but pressure drop will be higher. Maximum recommended velocity (liquid) through the sensor is 15 m/s. Beyond this point, cavitation may occur.  $Q_{min}$  is the recommended lowest flow rate. Sensors will measure flow rates lower than  $Q_{min}$ , but uncertainty may increase beyond 0.5% of rate.

These flow rate and pressure drop statements relate to standard pressure parallel tube sensor versions. Models with higher pressure ratings have increased wall thickness and will have higher pressure drops and lower  $Q_{nom}$  values.

## Measurement Performance

### Standard Calibration

|   |  |
|---|--|
| A | <b>0.5% Uncertainty</b><br>±0.5% uncertainty between $Q_{nom}$ and $Q_{min}$ |
| B | <b>0.2% Uncertainty</b><br>±0.2% uncertainty between $Q_{nom}$ and $Q_{0.2}$ |

Higher pressure units may have lower  $Q_{nom}$  values due to reduced tube ID

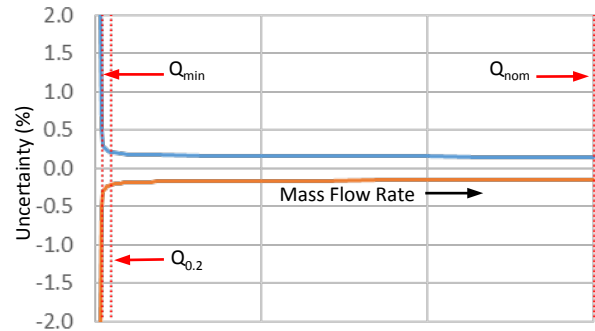

### Goldline Calibration

|   |   |
|---|---|
| G | <b>0.15% Uncertainty</b><br>±0.15% uncertainty between $Q_G$ and $(Q_G/10)$ |
|---|---|

Only for sensors with standard temperature and pressure range  
Customized calibration services are available – consult factory

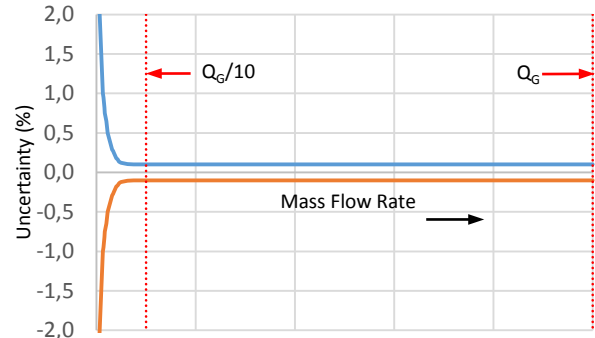

### Low Flow Calibration

|   |   |
|---|---|
| 2 | <b>Low Flow Optimized Calibration</b><br>±0.2% uncertainty between $Q_{0.2}$ and $(Q_{0.2} * 20)$<br>±0.5% uncertainty between $Q_{min}$ and $Q_{0.2}$<br>±0.6% uncertainty between $Q_{min}$ and $Q_{low}$ |
|---|---|

Only for sensors with standard temperature and pressure range

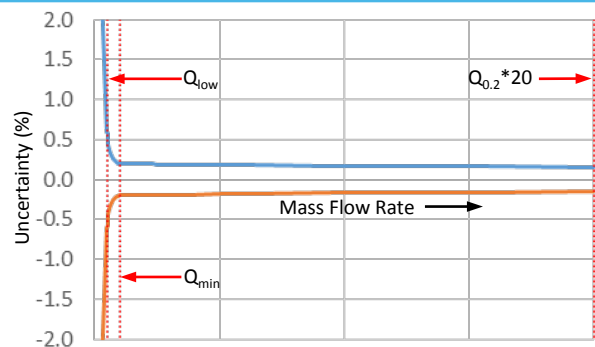

|           |                           |
|-----------|---------------------------|
| $Q_{nom}$ | 1500 kg/min (1653 lb/min) |
| $Q_{min}$ | 30 kg/min (33.1 lb/min)   |
| $Q_G$     | 1000 kg/min (1323 lb/min) |
| $Q_{0.2}$ | 60 kg/min (77.2 lb/min)   |
| $Q_{low}$ | 25 kg/min (22 lb/min)     |

Select the calibration option (A,B,G,2) required and include in the overall part number.  
For Serial Tube versions, the Q values above are halved

### Flow Measurement Repeatability

Standard ± 0.1% of rate  
Goldline ± 0.05% of rate

### Temperature Performance

Better than ±1°C

### Density Calibration

|    |   |
|----|---|
| N* | No Live Density Calibration   |
| S  | Standard +/- 0.005 kg/liter uncertainty between 500 and 1400 kg/m3  |
| D  | Enhanced +/- 0.0025 kg/liter uncertainty between 500 and 1400 kg/m3 |

For live volumetric flow, S or D calibration must be included in the part number and the sensor must be operated by an RHE with live density capability.

\* Even with No Live Density Calibration, volumetric flow can still be calculated with an inferred density value based upon a manually entered norm density value and its temperature gradient.

### Calibration Reference Conditions

Performance statements relate to the following conditions:

- Water (for mass flow accuracy)
- Temperature: 18 to 24°C (66 to 76°F)
- Pressure at 1 to 3 barg (15 to 45 psig)
- RHM with standard temperature, material and pressure range

## Measurement Tube Pressure Ratings

The maximum pressure ( $P_{max}$ ) of a sensor is determined by its lowest rated part. The lowest rated part can be either the measurement tube ( $P_{max}$  indicated below), the construction type ( $P_{max}$  indicated in the Part Number Code section) or the process connection (for  $P_{max}$  see published standards or manufacturer information).

| Pressure Code | Material Code | Material                            | Pmax                         |      |      |     |     |
|---------------|---------------|-------------------------------------|------------------------------|------|------|-----|-----|
|               |               |                                     | bar                          | psi  | @    | °C  | °F  |
| P1 (std.)     | M1 (std.)     | 1.4571 (316Ti)<br>UNS S31635        | 164                          | 2379 | @    | 50  | 122 |
|               |               |                                     | 147                          | 2132 | @    | 120 | 248 |
|               |               |                                     | 127                          | 1842 | @    | 210 | 410 |
|               |               |                                     | 107                          | 1552 | @    | 350 | 662 |
|               | M3            | 2.4602 (Alloy C22)<br>UNS N06022    | 253                          | 3669 | @    | 50  | 122 |
|               |               |                                     | 224                          | 3249 | @    | 120 | 248 |
|               |               |                                     | 191                          | 2770 | @    | 210 | 410 |
|               |               |                                     | 159                          | 2306 | @    | 350 | 662 |
|               | M4*           | Tantalum<br>UNS R05200              | 44                           | 638  | @    | 50  | 122 |
|               |               |                                     | 39                           | 565  | @    | 120 | 248 |
|               |               |                                     | 36                           | 522  | @    | 210 | 410 |
|               | 62**          | 1.4462 (Duplex)<br>UNS S31803       | 265                          | 3844 | @    | 50  | 122 |
|               |               |                                     | 232                          | 3365 | @    | 120 | 248 |
|               |               |                                     | 203                          | 2944 | @    | 210 | 410 |
|               | 10**          | 1.4410 (Super Duplex)<br>UNS S32750 | 332                          | 4815 | @    | 50  | 122 |
|               |               |                                     | 291                          | 4221 | @    | 120 | 248 |
|               |               |                                     | 263                          | 3814 | @    | 210 | 410 |
|               | P2            | M1                                  | 1.4571 (316Ti)<br>UNS S31635 | 257  | 3727 | @   | 50  |
| 230           |               |                                     |                              | 3336 | @    | 120 | 248 |
| 199           |               |                                     |                              | 2886 | @    | 210 | 410 |
| 167           |               |                                     |                              | 2422 | @    | 350 | 662 |
| 10**          |               | 1.4410 (Super Duplex)<br>UNS S32750 | 433                          | 6280 | @    | 50  | 122 |
|               |               |                                     | 380                          | 5511 | @    | 120 | 248 |
|               |               |                                     | 343                          | 4975 | @    | 210 | 410 |
| 62**          |               | 1.4462 (Duplex)<br>UNS S31803       | 346                          | 5018 | @    | 50  | 122 |
|               |               |                                     | 303                          | 4395 | @    | 120 | 248 |
|               |               |                                     | 265                          | 3844 | @    | 210 | 410 |

\* Only with N1, NA, E2 temperature range (note max. operating temp. is 130°C) and PFO construction type (max. ANSI 300/PN40)

\*\*Only with N1, NA, E2 temperature range (note min. temp. is -40°C) and seal-less construction type

## Other Materials and Pressure Ratings

Higher pressure rated measurement tubes in the materials above may be possible. Other wetted materials (e.g. Inconel, Monel, 304 stainless steel, others) are also possible for chemical compatibility, lower pressure drop, abrasion allowance and other application specific requirements.

Contact factory with specification for assessment and availability.

## Mechanical Construction

### Seal-less design

PF0: parallel/dual path

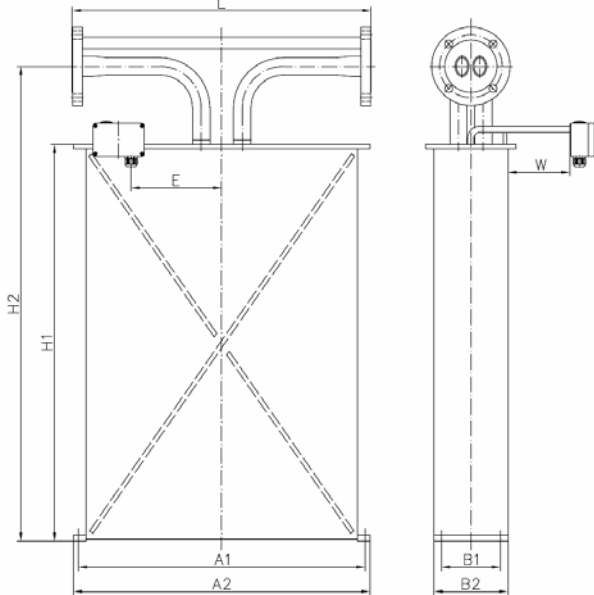

SF0: serial/single path

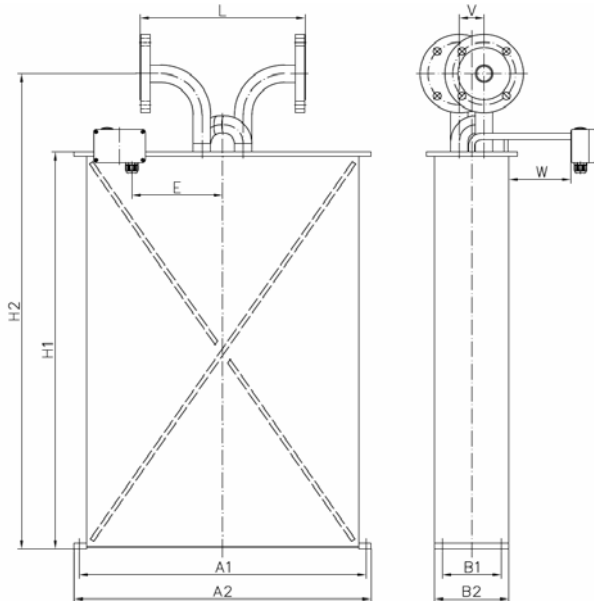

| Process Connection              |     | Dim. L      | Dim. H2      | Order Code |
|---------------------------------|-----|-------------|--------------|------------|
|                                 |     | mm / in     | mm / in      |            |
| ANSI 3" 150#RF                  | PF0 | 725 / 28.54 | 1153 / 45.39 | A1         |
| ANSI 3" 300#RF                  | PF0 | 725 / 28.54 | 1153 / 45.39 | A2         |
| ANSI 3" 600#RF                  | PF0 | 725 / 28.54 | 1153 / 45.39 | A3         |
| ANSI 3" 900#RTJ                 | PF0 | 725 / 28.54 | 1153 / 45.39 | A6         |
| ANSI 3" 1500#RTJ                | PF0 | 725 / 28.54 | 1153 / 45.39 | R6         |
| ANSI 3" 2500#RTJ                | PF0 | 725 / 28.54 | 1153 / 45.39 | R3         |
| DIN DN80/PN40                   | PF0 | 725 / 28.54 | 1153 / 45.39 | D1         |
| DIN DN80/PN100                  | PF0 | 725 / 28.54 | 1153 / 45.39 | D2         |
| DIN DN80/PN320                  | PF0 | 725 / 28.54 | 1153 / 45.39 | D9         |
| JIS RF 10k 80A (3")             | PF0 | 725 / 28.54 | 1153 / 45.39 | J1         |
| JIS RF 20k 80A (3")             | PF0 | 725 / 28.54 | 1153 / 45.39 | J2         |
| Sanitary 2in Triclam, DIN 32676 | SF0 | 300 / 11.81 | 1153 / 45.39 | S1         |
| Sanitary NW50, DIN 11851        | SF0 | 300 / 11.81 | 1153 / 45.39 | S2         |

1. For hub connectors (e.g. Destec, Galperti, Grayloc, Techlok) please consult factory
2. SF0 meters are constructed with offset inlet/outlet ports. Consideration should be given to the offset (dimension V) when planning installation
3. Listed ANSI, DIN, JIS flanges are also available for SF0 serial construction
4. Pmax for sanitary fitting S1 is 17.2 bar (250 psi) @ 120°C (248°F)
5. Pmax for sanitary fitting S2 is 25 bar (363 psi) @ 120°C (248°F)
6. Meter will be supplied with a 1.4571 (316Ti) stainless steel backing flange and wetted material facing disc for some material selections (e.g. Tantalum)

| Dimensions | mm  | in    |
|------------|-----|-------|
| A1         | 696 | 27.40 |
| A2         | 720 | 28.35 |
| B1         | 143 | 5.63  |
| B2         | 180 | 7.09  |
| H1         | 963 | 37.91 |
| V          | 60  | 2.36  |
| E          | 250 | 9.84  |
| W          | 150 | 5.91  |

**Standard blue terminal box in Aluminum, size = 125 x 80 x 57 mm (4.92 x 3.15 x 2.24 in)**  
- optionally available with integral RHE45 transmitter

Optional SS 316 box, size = 100 x 100 x 61 mm (3.94 x 3.94 x 2.40 in)  
- only for remote transmitter

*NOTE: Junction boxes are supplied with M25 x 1.5 cable entries as standard. M20 x 1.5, ½" NPT, ¾" NPT cable entries are optionally available and must be ordered separately.*

*All dimensions are for standard products. For customization of face to face length and/or process connection types other than the ones listed on this page, please consult factory. Note that larger diameter flange process connections are always possible.*

# RHM40L Part Number Code

**Temperature Range**

- N1 -20 to +120°C (-4 to +248°F) (std.)
- NA -50 to +120°C (-58 to +248°F)
- E2 -50 to +210°C (-58 to +410°F) (For Tantalum sensors max. operating temp. 130°C/max design temp. +210°C)
- E3 -196 to +50°C (-320 to +122°F)
- H4 0 to +350°C (+32 to +662°F)

**Pressure Code for Pmax of Measuring Loops (see pressure ratings page)**

See pressure ratings page for ratings and codes

**Construction Type**

- PFO Parallel path, seal-less
- SFO Serial path, seal-less

**Material of Wetted Parts**

- M1 1.4571 (SS 316Ti) (std.)
- M3 2.4602 (Alloy C22), seal-less construction types only
- M4 Tantalum, PFO construction type only, max. ANSI 300 / PN 40
- XX Other materials, e.g. (Super)Duplex are available upon request

**Process Connection**

See mechanical construction pages for available connections and codes

**Terminal Box Selection**

- JM Coated aluminum TB, M25 cable entry (options available)
- SM SS 316 TB, M25 cable entry (options available)
- TM No TB. 2m fixed / integral PTFE cable to RHE
- J5 Coated aluminum TB for integral RHE45, one or two M12 sockets

**Options Codes**

- NN No options

See options listing for specific codes

**Hazardous Area Certifications**

- NN Without Ex Approval
- A0 ATEX/IEC Approval Zone 0: Ex II 1G Ex ia IIC T1-T6 Ga
- A1 ATEX/IEC Approval Zone 1: Ex II 2G Ex ia IIC T1-T6 Gb
- C0 CSA Approval USA-Canada Class I, Div. 1, Groups ABCD

**Pressure Design Compliance**

- NN No specific design compliance required
- A2 PED [Europe] module A2 - unless unstable gas
- BC PED [Europe] module B3.2+C2 - if A2 does not apply
- CA CRN [Canada] - Alberta province
- CR CRN [Canada] - all other provinces

**Mass Flow, Density Calibration Selection**

See performance page for code options

**Additional Manufacturing Instructions**

- N None
- O Oil/grease free cleaning
- S Marine packing

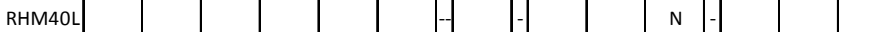

## Options and Accessories

| RHM40L Part Number Option Codes |  |
|---------------------------------|--|
| H1                              | Hot oil/steam heating matrix for housing, DN25 PN40      |
| H2                              | Hot oil/steam heating matrix for housing, 1" ANSI 150 RF |
| H3                              | Hot oil/steam heating matrix for housing, 1" ANSI 300 RF |
| P2                              | Housing purge connections - ½" NPT (2 pcs)               |
| SB                              | Housing in 316 stainless steel                           |
| DY                              | Dye penetrant inspection                                 |
| XR                              | X-ray test   |

NOTE: when specifying a sensor with multiple part code options (i.e. DY and XR), separate each code with a comma in the part string (i.e. ...DY,XR...)

| Cable Entry Options (order separately) |                                    |
|--|------------------------------------|
| ORHM-E1                                | ½" NPT Terminal Box Cable Entry    |
| ORHM-E2                                | M20 x 1.5 Terminal Box Cable Entry |
| ORHM-E3                                | ¾" NPT Terminal Box Cable Entry    |

Standard cable entry on terminal box is M25 x 1.5

## Transmitter Range



Any Rheonik Mass Flow Transmitter model can be combined with any Rheonik Mass Flow Sensor to provide an overall mass flow measurement system to suit any requirement. Rheonik Coriolis transmitters are available in versions specifically designed for process, industrial and OEM applications. Together they offer a tremendous range of options for system designers and end users alike.

See separate data sheet for the features of each transmitter style

## About Rheonik

Rheonik has a single purpose: to design and manufacture the very best Coriolis meters available. Our research and engineering resources are dedicated to finding new and better ways to provide cost effective accurate mass flow solutions. Our manufacturing group care for each and every meter we produce from raw materials all the way to shipping and our service and support group are available to help you specify, integrate, start-up and maintain each and every Rheonik meter you have in service. Whether you own just one meter or have hundreds, you will never be just another customer to us. You are our valued business partner.

Need a specific configuration for your plant - don't compromise with a "standard" product from elsewhere that will add extra cost to your installation. If we can't configure it from our extensive product range, our exclusive **AnyPipeFit Commitment** can have your flow sensor customized with any size or type process connection you need.

No matter what control system you use as the backbone in your enterprise, with our **AnyInterface Commitment**, you can be sure that connection and communication will not be a problem. Alongside a wide variety of discrete analog or digital signal connections, we can also provide just about any network/bus interface available (for example: HART, ProfibusDP, ProfiNet, EtherCAT, PowerLink, EtherNet/IP, CAN, ....) with our RHE4x family of transmitters. Rheonik RHE4X transmitters can connect to your system – no headache and no conversion needed.