



# 5 VDC OUTPUT HIGH ACCURACY DIGITALLY CORRECTED INDUSTRIAL APPLICATIONS PRESSURE TRANSDUCER

## APTE-DC-1100 SERIES

- 5 VDC Digitally Corrected Output
- Rugged All Welded Construction
- Excellent Long Term Stability
- Silicon on Silicon Integrated Sensor **VIS<sup>®</sup>**
- Analog Output
- High Overload Capabilities
- Intrinsically Safe Applications Available (i.e. IS-APTE-DC-1100)



The ingenious application of modern solid state technology to pressure sensing makes the APTE-DC-1100 Series the most advanced pressure transducer available of its class. Designed to measure liquid or gas pressure, the transducer is of all-welded stainless steel construction, with integral pressure port and isolation diaphragm. The APTE-DC-1100 provides an extremely rugged, accurate and inexpensive means for pressure-to-voltage conversion. The output, and the ability to withstand high voltages between leads and case make the APTE-DC-1100 Series Transducers ideally suited for a large number of high accuracy industrial or flight test applications.

The APTE-DC-1100 is a 5 volt unit containing a hybrid microelectronic digital correction amplifier and regulator within the all welded case.

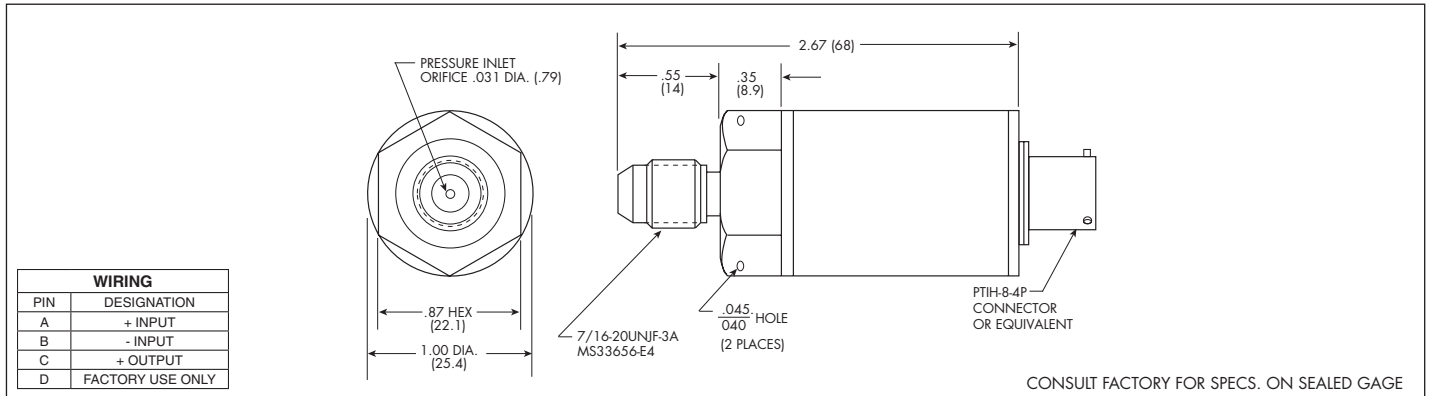

INPUT	Pressure Range	1.7 25	3.5 50	7 100	17 250	35 500	70 1000	170 2500	350 BAR 5000 PSI	
	Operational Mode	Absolute						Sealed Gage		
	Over Pressure	2 Times Rated Pressure								
	Burst Pressure	5 Times Rated Pressure Range to a Maximum of 20000 PSI (1400 BAR)								
	Pressure Media	Any Liquid or Gas Compatible With 15-5 PH or 316 SS								
	Rated Electrical Excitation	12 ± 4 VDC or 28 ± 4 VDC (Reverse Polarity Protection Available Upon Request)								
	Maximum Electrical Current	25 mA (Max.)								
OUTPUT	Output Impedance	50 Ohms (Typ.)								
	Full Scale Output (FSO)	5 VDC								
	Residual Unbalance	0.5V								
	Total Error Band	± 0.2% (Typ.) (±0.4% Typ. for 25 PSI (1.7 BAR) (End Point Settings, Combined Non-Linearity, Hysteresis, Repeatability and All Thermal Effects Included)								
	Amplifier Bandwidth (-3dB)	Optional Bandwidths DC to 2500 Hz or DC to 10 KHz								
	Resolution	Infinitesimal								
	Insulation Resistance	100 Megohm Min. @ 50 VDC								
ENVIRONMENTAL	Operating Temperature Range	-40°F to +257°F (-40°C to +125°C)								
	Compensated Temperature Range	-40°F to +250°F (-40°C to +120°C)								
	Linear Vibration	50g Peak, Sine 10 to 2000 Hz								
	Humidity	100% Relative Humidity								
PHYSICAL	Mechanical Shock	100g half Sine Wave 11 msec. Duation								
	Pressure Port	A. 33656/E4 7/16-20 UNJF-3A			B. 1/4"-18 NPT Male			C. Other Ports Available		
	Electrical Connection	PTIH-8-4P or Equivalent								
	Weight	120 Grams Approx.								
	Pressure Sensing Principle	Fully Active Four Arm Wheatstone Bridge Dielectrically Isolated Silicon on Silicon								
Mounting Torque	80-100 Inch-Pounds (Max.)									

Note: Custom pressure ranges, accuracies and mechanical configurations available. Dimensions are in inches. Dimensions in parenthesis are in millimeters. All dimensions nominal. (M) Continuous development and refinement of our products may result in specification changes without notice. Copyright © 2014 Kulite Semiconductor Products, Inc. All Rights Reserved.

